

VisioPointer®

A Plug and Play Vision system for efficient packaging inspection, production digitalisation and optimization.



Inspection
Types



Seal



Label & Artwork



Barcode



Print



Top Inspection



Side Inspection



Bottom Inspection

VisioPointer® reliably automates inspection processes in food packaging lines using leading vision technology and multiple inspection types.

Thanks to its seal inspection functionality VisioPointer® is ideal for the inspection of thermoformed packaging, sealed tray packaging, skin pack, and sealed plastic cups.

Its intuitive interface and intelligent data usage allow operators to ensure product quality, reduce waste and downtime, and optimize the production.

As a plug and play vision solution, VisioPointer® makes thorough quality control achievable for any food manufacturer with easy implementation, operation and maintenance.

Highlights

- Automated, complete end-of-line inspection
- Ideal for inspection of MAP and vacuum packaging
- Stand-alone unit with built-in operator panel & ejector
- Intuitive interface for efficient operation
- Quick changeovers and product teach-ins
- Real-time data overview of production performance
- Cloud-enabled Production Intelligence
- ERP/MES connectivity
- Control your fleet with Central Product Management.

VISIOPINTER® Inspection Examples

VisioPointer® reliably and accurately detects errors exceeding the set desired quality level. Following examples show some of the errors that VisioPointer® detects and rejects.

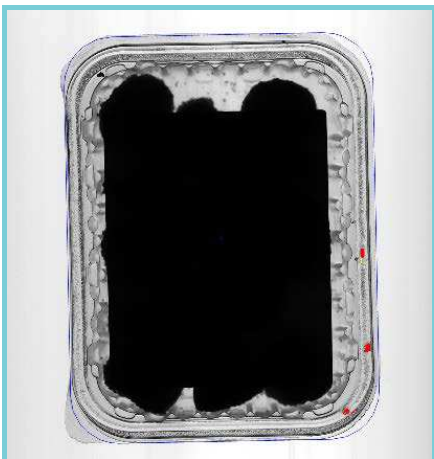

Seal contaminations

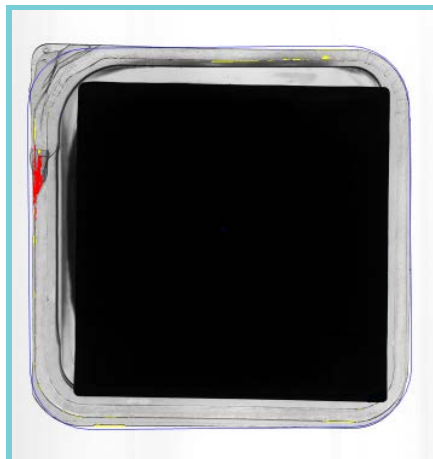

Welding errors



Misplaced labels



Wrinkled labels



Unreadable barcodes



Unreadable prints

VISIO POINTER® Technical Data

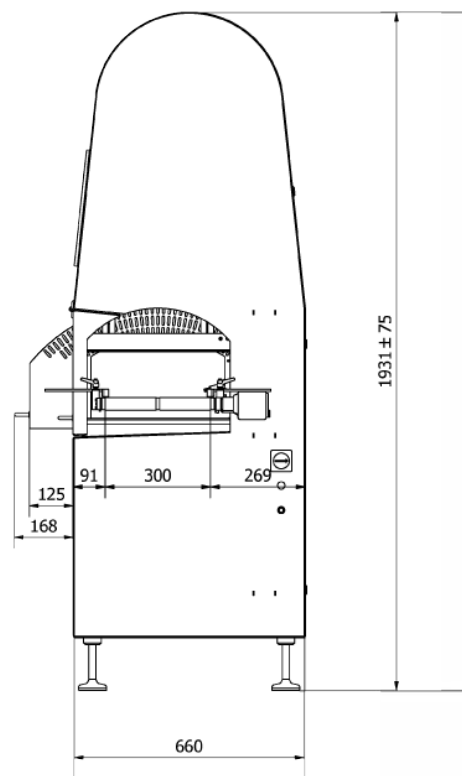
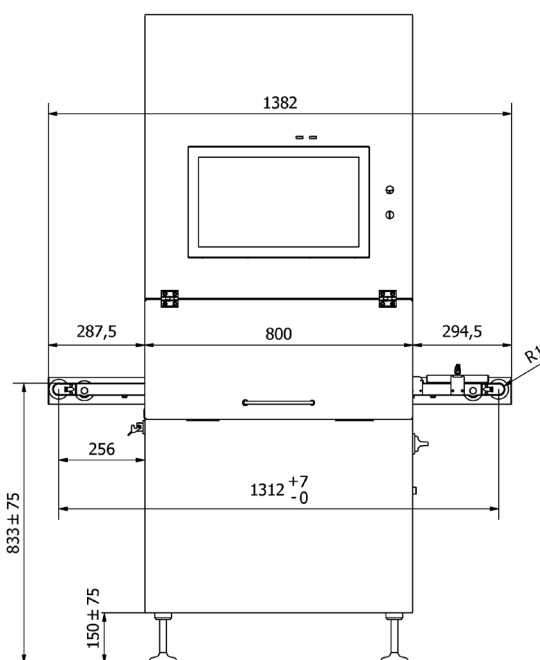

Inspection Specifications

Cameras	GigE Line Scan
Max. dim. of inspected product	110H x 280W x 350L mm
Max. conveyor speed	800 mm/s

Mechanical Specifications

Material	Stainless steel AISI 316 Encap. parts: Stainless steel AISI 304
Dimensions (excl. shield)	1930H x 1382W x 660D mm
Weight	350 kg
Conveyor dimensions	1400W x 300D mm
Conveyor level	900 mm (+ / - 50 mm)
Ejection mechanism	Mechanical pusher (Standard)
Enclosure Rating	IP 64

Built-In Computing System

Processing system	Industrial PC
Operating system	Windows 10 IOT Enterprise LTSB
Interface	Gigabit Ethernet and digital I/O
Communication protocol	OPC UA and REST
HMI	21,5" full HD multi-touch panel
Language	All languages available

Supply

Voltage	230VAC / 50 Hz, Max 13A
Power	2,5 kW
Pneumatic	8 - 10 bar